

Canning Creations



Canning Arts Group

Like us on Facebook



Follow us on Instagram

ISSUE 70

October 2024

Canning Arts Group thanks the City of Canning for its continued support.



This bi-monthly newsletter is distributed to members of the Canning Arts Group, and a limited number of printed copies are available from the office at Canning Arts Centre between 9.30 and 1pm weekdays.

Contributions from members are welcome.

Committee Roundup

Well here we are with spring upon us and wonderful sunny days. All the gardens are coming back to life and we are busy producing new art pieces getting ready for the sales in the coming months.

All our shelving has been installed in the students area and hobby room which has given more room to store students work, and our colorful stools are arranged in the pottery area making the area a little brighter.

Erin from The Art Trail has been keeping in touch with us and we have Sue from the committee who will be attending their meetings and keeping in touch with what is happening. We haven't heard too much of what is happening as yet.

Thank you to Chris Goldberg for all the organizing of

the Canning Art Exhibition at the library, and to the members who have given their time, helping out with hanging and doing rosters. I hope some of our Artists sold their Art in the Exhibition.

We had a lovely morning tea today for Rosy, one of our very special members who has done so much for us, helping pottery teachers, doing children's classes, always ready to help with activities that are happening at the Art Centre. Best Wishes and happiness for your new adventure in Albany, I am sure you will get quite a few members catching up with you down there when they are passing by.

Thank you John for your fun night with your Paint and Sip, there was great music,

plenty of laughter from our members and I was shocked to see my painting did resemble yours. Hopefully there will be more of these fun social events to enjoy.

The next couple of months are very busy with Cagstock coming up on the 5th and 6th of Oct. Don't forget all members are invited to come down and socialize while creating your art, it starts at 10am on the Saturday and goes until 4pm on Sunday, lots of fun. Please bring something to share for lunch and dinner.

Then on the Tuesday 5th of November, Hobby Day, there will be a lunch for the Melbourne Cup, come down and join in a sweep and watch the race, please bring a plate to share.

At the beginning of December we will have a big clean and set up for the Xmas sale and would like our members to help out at this time. We have a large membership so please come down and help out so it's not left to just a few. The Xmas sale is for all the members to participate in to sell their Art, so make sure you are there to clean and set it up.

Its that time of the year where we are all busy with exhibitions and making work for the sales, but do take some time to enjoy the lovely weather and I hope to see you at Cagstock.

Cheers Jill

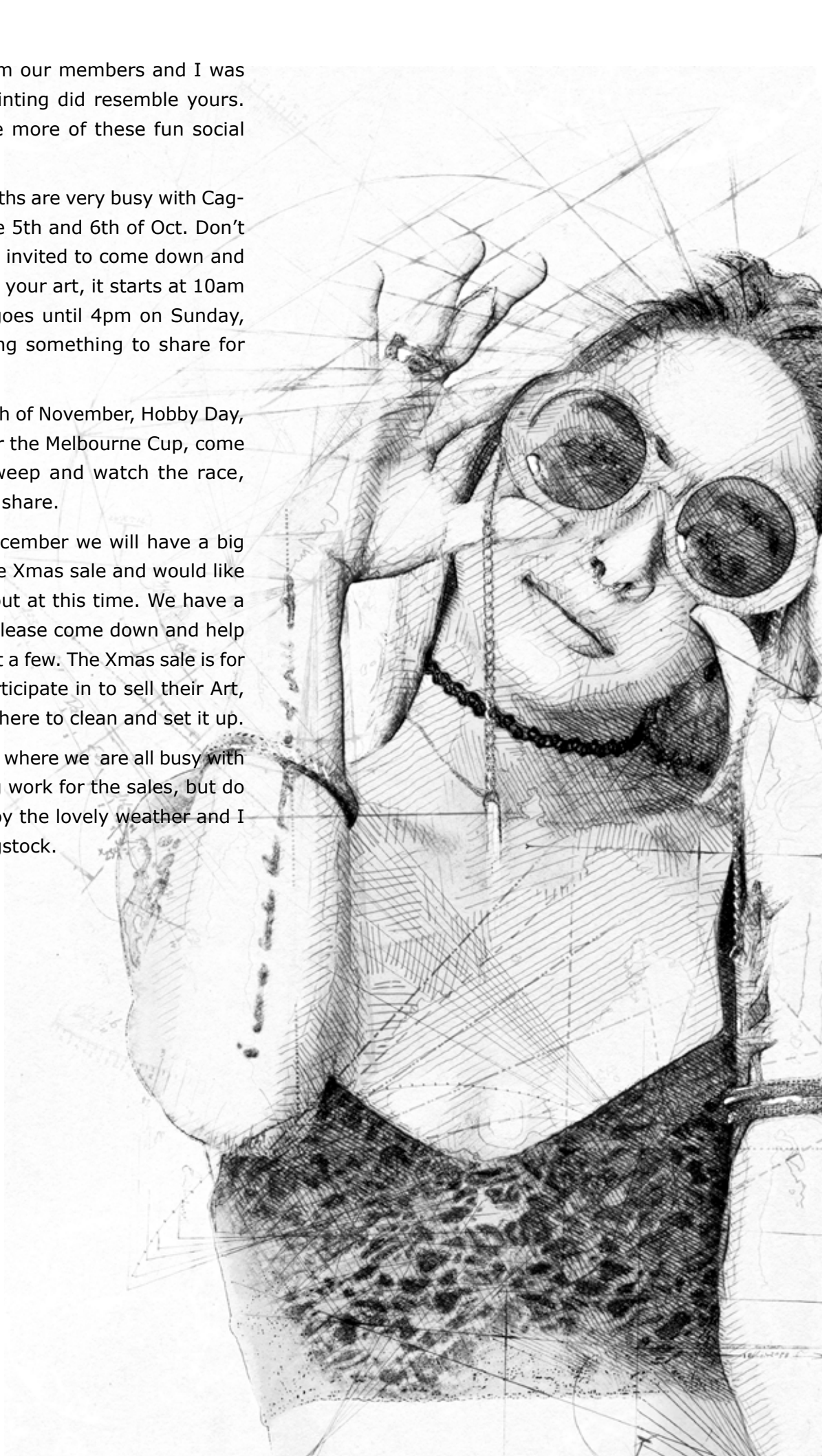



Coordinators Corner

Hi Members,

Wow 2024 is running out fast! Term 4 classes start from the week commencing 7th of October and before you know it the end of year events will be upon us!

Some important dates for your calendar:

- All hobby days will finish up on the week ending 30th of November 2024
- The office will be closed from the 15th of December 2024 and will reopen from Monday 6th of January 2025. For access to the centre during this time, Members need to arrange a key through our key holders: Trish Ray – 0434 556 453, Chris Taylor – 0427 571 513, or Jill Archibald – 0407 995 649.
- All Hobby days will resume from the week commencing 6th of January 2025

Some other key dates coming up:

- We still have availability in quite a few of our Term class for Term 4, so check them out on the website and book now.
- CAGSTOCK is coming up this weekend from 10am Saturday 5/10/24 to 4pm Sunday 6/10/24 – come along and spend an enjoyable weekend at CAG full of Art and pottery.
- We have a new Beginners Oil Painting 5-week workshop commencing 23/10/24 – go to the website for details.
- A Paint and Sip night on Saturday 16/11/24 – see website for details.

In the coming weeks as we wind down 2024, we will be sending out re-enrolment emails for Term 1 2025, and also an email for renewing your membership for 2025. (Only current members will be able to renew their membership online – new members will need to complete the membership form and make payment through the office).

The wonderful committee is busy organising both the Christmas Sale of Works and the End of Year Exhibitions, so hopefully you'll have works ready to go for these events – more details

to come on when we will need these by, in the Weekly Round-up Email.

Please also have a think about joining the committee in 2025. Without our committee the Canning Arts Group cannot exist. We are looking for a new Treasurer for 2025, so if you have experience in this area, the Committee would love to hear from you.

We would like to take this opportunity to thank all members who have helped out during the year in any capacity. Your assistance even if it was a small task enables the smooth running of the place.

Mio and I will be taking a bit of time off in the next couple of months. I will be away from 14/10/24 to 27/10/24 and Mio will be away from 6/11/24 to 19/11/24.

That's all from us for this issue.... See you soon!!

Juls & Mio

HOBBY DAYS

Painters

Tuesday 12.30pm – 3.30pm

Friday 9.30am – 12 midday

Potters

Tuesday 9.30am – 3.30pm

Glassies

Thursday 9.30am – 3.30pm





2024 CAG Calendar

Monday 1 January	News Years Day
Monday 8 January	Office Opens
Friday 26 January	Australia Day
Monday 5 February – Thursday 28 March	Term 1
Monday 4 March	Labour Day
Tuesday 5 March	Annual General Meeting
Friday March 29	Good Friday
Monday 1 April	Easter Monday
Tuesday 2 April – Friday 12 April	April Artsfun
Monday 22 April – Saturday 22 June	Term 2
Thursday 25 April	ANZAC Day
Monday 3 June	WA Day
Monday 1 July – Friday 12 July	July Artsfun
Monday 22 July – Saturday 21 September	Term 3
Saturday 21 September – Saturday 28 September	Canning Art Awards
Monday 23 September	King's Birthday
Tuesday 24 September – Friday 4 October	September October Artsfun
Sat 5 – Sun 6 October	CAGSTOCK!
Monday 7 October – Saturday 30 November	Term 4
Monday 2 – Tuesday 3 December	Centre Clean
Wednesday 4 – Sunday 15 December	Xmas Sale

Canning Arts Group Gallery Calendar 2024

Exhibit Title	Exhibit Notes	Item Drop off closes	Exhibition Dates
Scale	Dial into your creativity and weigh in on the array of interpretations of this short but versatile word. From proportions & precision, to musical harmonies, rainbows of colour and the protective role it plays in nature. Be part of an exhibition sure to scale new heights!	Thursday, 25 January 2024	Monday, 29 January 2024 to Thursday, 28 March 2024
Life in the Urban Forest	Our city is more than just houses and streets – it is a living, breathing urban forest. Where trees flourish - so do we. We invite artists to consider this symbiotic bond with our silent, leafy friends and share interpretations and observations of our lives amidst this urban forest.	Friday, 5 April 2024	Monday, 8 April 2024 to Friday, 17 May 2024
Time After Time	Rhythms, repetition, and cycles. Through your artistic lens, delve into the essence of patterns, consistency, and growth with a focus on patterns and sets.	Friday, 17 May 2024	Monday, 20 May 2024 to Friday, 12 July 2024
Age	Embrace the beauty of youth and the character of age. Capture rustic charm and weathered resilience through textures and tones. Celebrate the vibrancy of youth in all its hues. Reflect on the stories that unfold with time in life's ever changing phases.	Friday, 12 July 2024	Monday, 15 July 2024 to Friday, 30 August 2024
Out of this World	Unleash your creativity and transport us to worlds unfamiliar. Let your imagination run wild and delve into themes of fantasy, the future, the past, space, magic and abstract.	Friday, 23 August 2024	Monday, 26 August 2024 to Friday, 11 October 2024
Tiny	Does size really matter? How small can you go? The Tiny exhibition challenges you to showcase your creativity within the dimensions of 100x100x100mm Make every inch count in these petite dimensions.	Friday, 11 October 2024	Monday, 14 October 2024 to Friday, 29 November 2024
Schools Out!	It's time to shine at the Schools Out exhibit. Share what you've crafted, moulded, or painted in classes and workshops over the year. Inspire and be inspired by what others are making.	Friday, 11 October 2024	Monday, 14 October 2024 to Friday, 29 November 2024

Dates For Your Diary



ARMY ART

\$35
OPENING NIGHT
Get Your Tickets
NOW!
7PM Friday 25th October 2024
The 49th Art Show
presented by Army Art (WA) Inc
www.stickytickets.com.au

Opening Night tickets are available for the 49th Army Art Show, 7pm Friday 25th October. Historic hall, Leeuwin Barracks, East Fremantle.

Numbers are limited, so don't miss out.

<https://www.stickytickets.com.au/WKH9E>

Art Exhibition
SHOWTIME!
Featuring canvas, ceramic, textile and wooden art
By Western Australian Artists

Barb Green Chris Britza Liz Ford

Showing
Saturday 26 to Sunday 27 October 2024
9am to 4pm
@
Canning Bridge Art Space
63 Kishorn Road,
Mount Pleasant WA

Your Invitation
You and three friends are invited to attend the exhibition opening on **Saturday 26 October at 2pm** to help the artists celebrate their creative effort, collaboration and love of art. Refreshments will be provided.

Chris Britza is one of our long standing life members.



Paint & Sip



Our inaugural Paint and Sip event was a resounding success.

Next one will be in November, see notice in following pages.



2024 Canning Art Awards





Let's Talk Safety

Have you ever had a bit of a close call or near miss, and just avoided an accident big or small?

We don't want that to happen here at Canning Arts Centre, so here are just a few reminders to keep you and others safe and well:

- Be aware of spills and splashes and mop up any wet patches on the floor or surfaces straight away – even if you didn't cause the spill yourself.
- Use the wet floor signs to warn others of potential slipping hazards.
- Share the load and ask for help. Don't attempt to carry or lift heavy, or multiple items yourself.
- If you make a mess, clean it up, and return used resources to where they belong.
- Take care with where you leave personal items – bags left on the floor should be tucked away so not to cause a trip hazard.

Be creative, be safe and enjoy!

Debbie Brown

SAT
16
NOV

PAINT & SIP NIGHT

MUSIC & ENTERTAINMENT



HOOT HOOT

TIME

6.30 - 8.30

LOCATION

72 Riley Road
Riverton wa 6184

office@canningartswa.org.au

0484 554 977

BYO

WINE & BEER

BOOK NOW

\$55

PER PERSON

Travel Tales

A place to share your travels and Public Art you have seen

Sue Clark

Kev and I went down to Margaret River for the Artists' Open Studios and managed to see over 40 artists in four days. The range of art varies a lot and it's always interesting to see different art



forms. I found Wayne Cherrington's mosaic display in Augusta well worth the drive. Kerry Silby's sculptures were fantastic and I even managed to

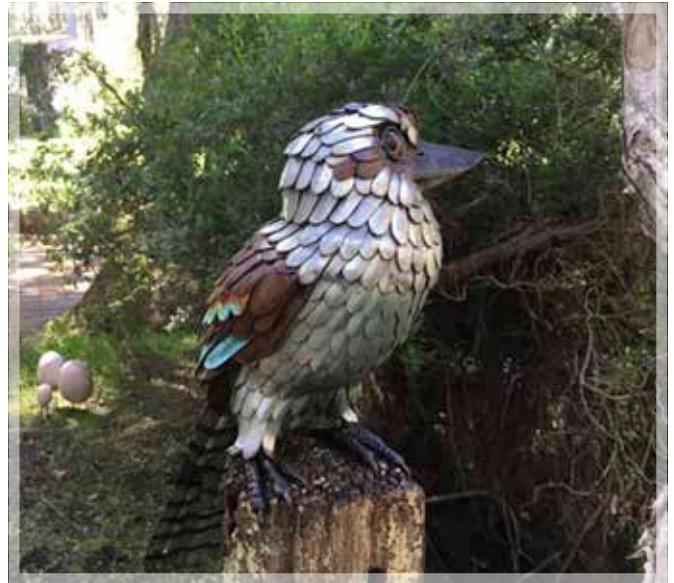

see Honor Denby who was a CAG member some years ago.



Farewell Rosy



CAGSTOCK

this weekend - October 5-6
10am Saturday - 4pm Sunday

Our Art Centre is open to members
all weekend.

Come join us and spend a fun
weekend creating your art and
socialising.

BYO drinks and food.
Please bring a plate to share for lunch
and the evening meal.

SIZE MATTERS

TINY

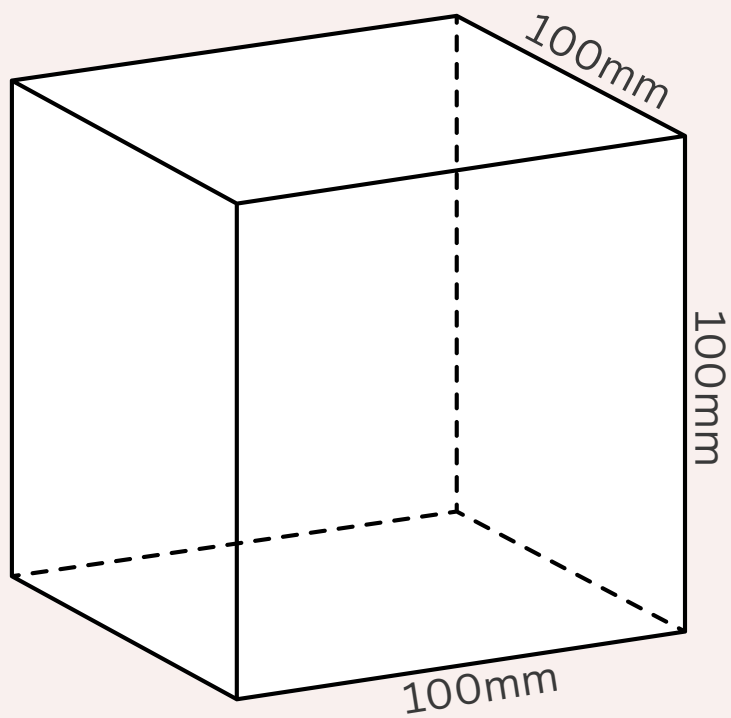

Monday, 14 October 2024 - Friday, 29 November 2024

Canning Arts Group

Monday, 14 October 2024 to

Friday, 29 November 2024



It's time to shine at the Schools Out Exhibition.

Share what you've created this year in classes, workshops or wherever you like to create.

Canning Arts Group

Whats on your

Easel/Wheel/Table

Marion Mouttet



Karen Ball



Sue Clark WIP

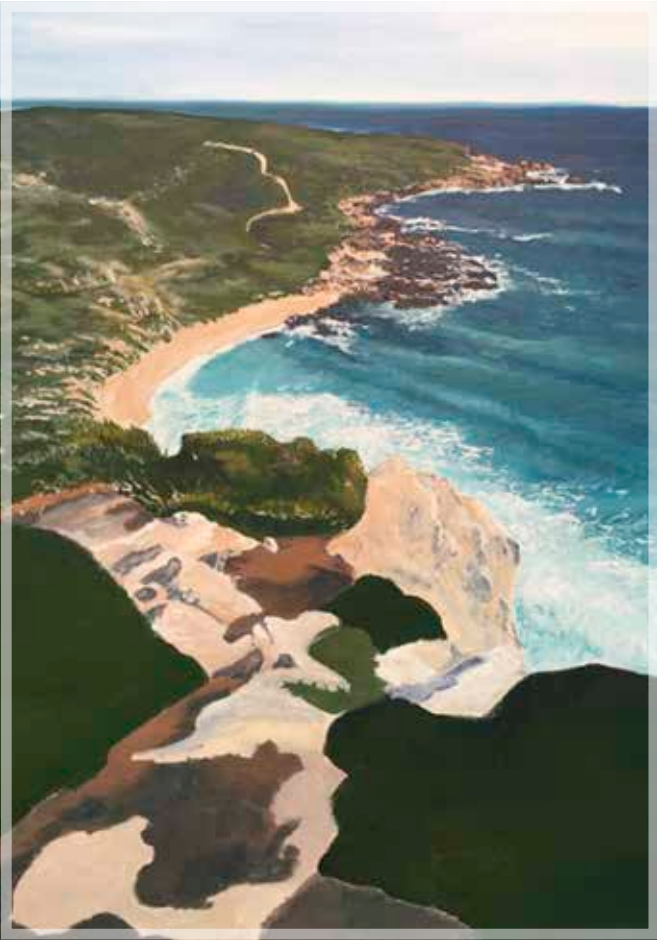

Alison Hanrahan WIP

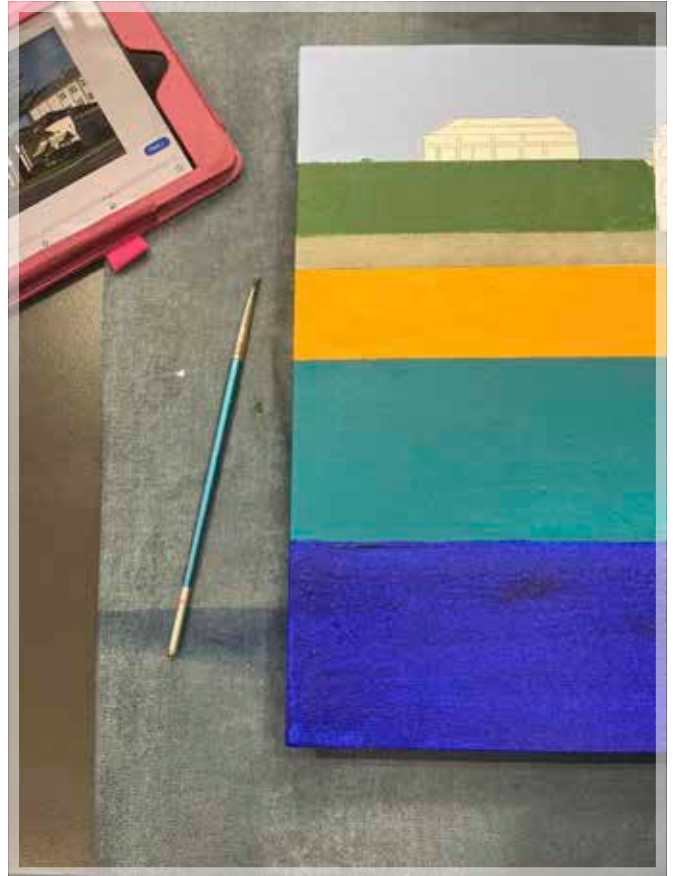

Debbie Brown WIP



Graham Longworth WIP



Kimmi



Anne Kraslan WIP



Trish Ray WIP



Pam Bradley WIP



Debbie Brown WIP



Jeff Armstrong



Chris Goldberg WIP



John Guilfoyle WIP

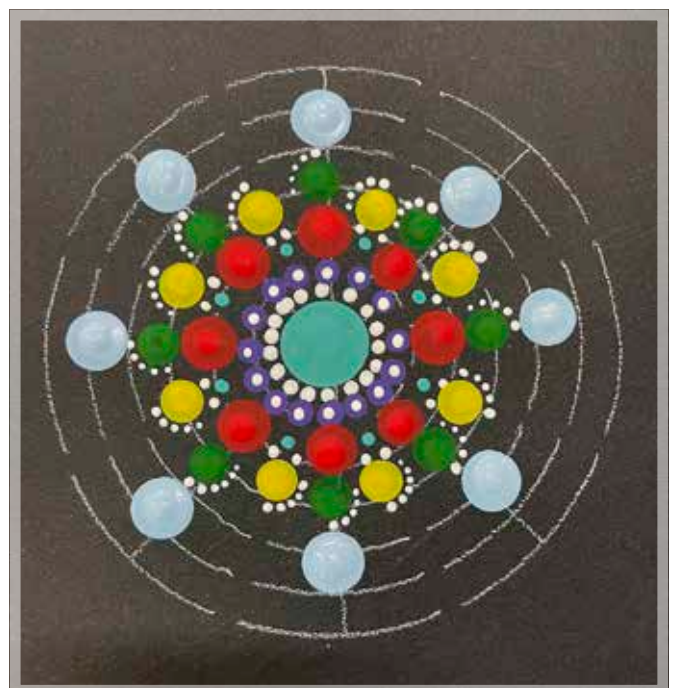

Lyn Owen WIP



Karen Ball WIP



Colin Muscroft WIP



Sue Clark

I've been doing quite a lot of sewing for the grandchildren lately. It can be quite challenging at times but it is very rewarding when things work out well. We have three more babies on the way, so I'm being kept busy in the sewing room.



Potters Page

Hobby Day Tuesdays 9-30 to 3pm



Rebecca and Mel did a very successful gas firing last week, with a good reduction and lovely colours.



Whats on Your Bookshelf



The Way We Are

by Hugh Mackay



Australia's leading social psychologist examines our society today and asks timely and urgent questions about its future

Life is messy. Relationships are complex. Outcomes are uncertain. Yet none of our differences—whether based on ethnicity, politics, religion, cultural tastes and

preferences, or gender—are nearly as significant as the humanity we share.

Amidst our epidemics of loneliness, anxiety and depression, and the impacts of entrenched poverty and ubiquitous technology, *The Way We Are* examines the major trends that are shaking the foundations of the Australian way of life.

Drawing on thousands of interviews over a lifetime of research, Hugh Mackay, much loved and highly respected social psychologist, presents a compelling portrait of Australia today. He celebrates the march towards gender equality and explains the stubborn persistence of misogyny, the anti-social consequences of social media, the complex legacy of the Baby Boomers, and the 'fake wisdom' that guides too much of our thinking. Exploring the steady decline in religious faith and practice, Hugh identifies the many gods we continue to worship, and points to the positive role that dreaming can play in our lives. Though some of his observations may not be easy reading, Hugh's analysis is

suffused with affection for our country.

Inspiring, provocative and powerfully argued, *The Way We Are* is the most important—and uplifting—book you'll read all year. It will encourage you to reflect deeply on the question: What kind of society do we want to become? (Amazon)

This was an interesting book. Some of the ideas were a bit uncomfortable to think about and Hugh covers many areas of daily life that we rarely consider.

Slow

by Meredith Gaston Masnata



The Philosophy of Simple Living explores the idea of slow living to find happiness by stepping away from the never-ending demands to constantly succeed and acquire more and more. It's easy to become caught up in frantically wanting, buying, and upgrading the things in your life.

Constantly striving, we feel exhausted and deprived in the midst of great abundance. The philosophy of The Philosophy of Simple Living is about finding the freedom to be less perfect and taking time to enjoy the pure joys of a walk in the forest, sharing laughter with family, a personal moment of gratitude. Living a meaningful life that has connection, joy and beauty can be found in every moment. Slow, sweet living honors living with appreciation and reverence, and respects daily life as an inherently awe-inspiring and sacred experience. In a

slower life we derive inspiration from meaningful conversations and fleeting daily encounters alike. We become mindful of what we are striving for in this life. Indeed, by living daily life more slowly, we come to understand what matters most to us – reconnecting with peace and joy. (Goodreads)

I love Meredith's books. They are beautifully illustrated and full of wisdom and suggestions for a fulfilling life.

Art Hour at the Duchess Hotel

by Sophie Green

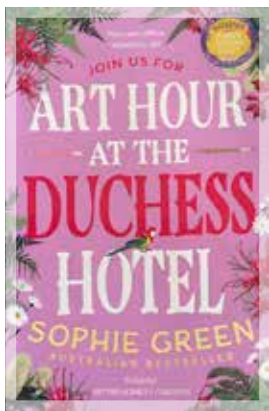

Mornington Peninsula, 1999. Wife and now grandmother Joan has checked into the grand old Duchess Hotel to find herself again after thirty-five years of being who her husband and family have wanted her to be. Peninsula local and soon-to-be octogenarian Frances is distracting herself from

getting old, and avoiding her self-interested son by escaping to the warmth of the Duchess where the hotel staff treat her like the person she still is. Meanwhile Frances's daughter, Alison, is trying to manage significant disruptions at home while hoping to finally prove to her mother that she's just as worthy of love as her brother. New to the Duchess, hotel maid Kirrily is feeling the weight of a lifetime of responsibility, struggling to balance bills and work and family, and keeping thoughts of how there must be more to life at bay.

With its old-world glamour, sprawling seaside grounds and air of possibility, the Duchess Hotel might just be the place to help the women rediscover who they are and bring some spark back to their lives.

When Joan decides to pick up a brush and start painting for the first time in decades, she inspires Frances and Kirrily - and, eventually, Alison - to join her. Over canvas, conversation and creativity

they will learn that you should always hold onto your dreams and that new friends can give you the courage to live life on your own terms.

(Goodreads)

This novel is a good summer holiday read. Fairly predictable but the characters are relatable and the story line hooks you in.

Girl in Pieces

by Kathleen Glasgow

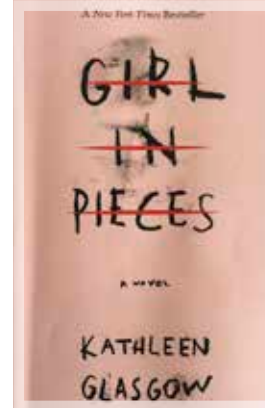

Charlotte Davis is in pieces. At seventeen she's already lost more than most people lose in a lifetime. But she's learned how to forget. The broken glass washes away the sorrow until there is nothing but calm. You don't have to think about your father and the river. Your

best friend, who is gone forever. Or your mother, who has nothing left to give you.

Every new scar hardens Charlie's heart just a little more, yet it still hurts so much. It hurts enough to not care anymore, which is sometimes what has to happen before you can find your way back from the edge. (Goodreads)

I didn't realise that this is a book for young adults, and it is very gritty and shocking in parts. Yet it is positive in some ways and gives the message that there is always hope.

Sue Clark



Recipe Corner

Yes cooking IS an art form

This is a place to share your favourite recipes

Chicken cooked in buttermilk with fresh tarragon



Ingredients

- 6 small chicken Marylands
- 1 onion, chopped
- 3 garlic cloves, chopped
- 1 cup white wine
- 1 tbsp chopped fresh tarragon
- 1 tbsp chopped fresh dill
- 1 tbsp honey
- 2 tsp hot English mustard
- 1 cup buttermilk
- 1 big fennel bulb, in wedges
- 1 cup peas

- In a baking dish, melt the butter on the hot-plate. Brown the chicken pieces. Then add the onion and garlic. Cook for a few minutes to soften onion.

- Add the wine, tarragon, dill, honey and mustard. Bring to the boil, and then simmer for a few minutes. Next stir through the buttermilk.
- Place in the oven, covered with foil and bake for 45 minutes at 180C. Remove the foil and add the fennel.
- Cook uncovered for another 15 minutes. Remove from the oven and add the peas. They should cook enough in the hot liquid.
- Serve garnished with extra tarragon or dill.

Broccoli Salad

With smoky bacon, tomatoes & chives 2 large heads of broccoli



Ingredients

- 6 rashers of smoked streaky bacon
- olive oil

Dressing

½ a clove of garlic

2 teaspoons Dijon mustard

6 tablespoons extra virgin olive oil

2 tablespoons white wine vinegar

- Use a small knife to remove the broccoli florets and cut them up into smaller ones. You'll be left with the stalk, so discard the thick dry base, then cut the remaining stalk in half lengthways and finely slice.
- Blanch your broccoli florets and sliced stalks really quickly in boiling salted water for 60 seconds. Drain it in a colander, then spread it around a clean tea towel to steam dry (this is important because it will help the dressing cling to the broccoli). Once completely dry, transfer to a serving dish.
- Finely slice the bacon and fry on a medium heat with a small splash of olive oil until crisp and golden, then spoon most of the bacon bits over your broccoli.
- Any leftover fat in the pan can be used in your salad dressing. Pour it into a mixing bowl, then peel and finely grate in the garlic. Add all the other dressing ingredients, season with sea salt and black pepper, and whisk.
- Halve, deseed and finely slice the tomatoes and chop the chives, reserving the flowers. Add to your broccoli and bacon bits. Dress it all really well, and check the seasoning. It's beautiful on its own or served next to any grilled or roasted meat or fish. (Jamie Oliver)

Chris Goldberg



Canning *Creations* Classifieds

A place for members to buy, sell or gift freely :)

FOR SALE

Honeywell Evaporative Air Cooler

Model No.: CS10XE

Price: \$150.00 ONO

Pick up at

Canning Arts Centre

72 Riley Road, Riverton WA 6148

Contact CAG Office 0484554977



Resources for Artists

Don't forget our Canning Arts Library situated in the metal cupboards in the painters hall and the bookcase just outside the pottery area. These are there for your use, simply put your name in the book provided if you would like to borrow one.

NB All the links below are live, so if you are reading this on a tablet or computer, just click on them and Acrobat will ask for permission to go there.

If anyone has other links they think may be of value to our members, email me and I will include next time.

Chris Goldberg

<http://www.artsource.net.au>

Established in 1986, Artsource is the peak membership body for visual artists in Western Australia. Their purpose is to engage with and support Western Australian visual artists with practical, affordable and relevant services.

<https://www.artistsnetwork.com>

Subscription based, live stream or purchase training videos, magazines, and books in all mediums

<http://www.wetcanvas.com>

The largest community for visual artists on the Internet!. It is comprised of artists of all levels, ranging from Sunday painters to artists who exhibit in some of the finest galleries in the world. Whether your interests lie in learning new techniques, experimenting with alternative or cross-over mediums, gaining critiques from fellow artists, or getting the scoop on exciting new industry products, WC has something for you, including a full online library of reference images.

<https://www.pmp-art.com>

Paint My Photo (PMP) is a social networking site dedicated to sharing photos for artistic inspiration without fear of infringing copyright, something we all need to be aware of if we intend selling our work.

<https://www.nma.art>

Subscription based. Learn from the world's top artists in a variety of styles and approaches, with a focus on foundation. Unlimited streaming courses means you can learn anywhere, anytime, no matter how busy your schedule. With streaming plans starting at US\$35/month.

<https://brightlightfineart.com>

Subscription based. Fine Art Drawing and Painting Classes, by David Leffel, Sherrie McGraw, Jacqueline Kamin & Stacy Kamin

<http://www.fitzroystretches.com/>

Art supplies, east coast but with free shipping, and if you want to make your own canvases, this is a good place to buy stretchers.

<https://www.oxlades.com.au/>

Art supplies. Perth

<http://www.hukendall.com.au/>

Art Supplies. Perth

<https://www.jacksons.com.au/stores>

Art supplies. Perth

<https://thepottersmarket.com.au/>

Based in Stockdale Rd, O'Connor-Pottery Supplies, Raw materials, clay, tools and equipment, firing services

<https://pottersonline.com.au/index.html>

The Australian Ceramic Art & Pottery resource network

<http://ceramicartsdaily.org>

Subscription based, live stream instruction videos, buy videos

<http://www.claytimes.com>

Ceramic Art Trends, Tools, and Techniques for Potters Worldwide

<http://keaneceramics.com.au>

Keane Ceramics is one of the country's largest clay producers, suppliers and online retailer of our renowned clay range, pottery equipment, raw materials, tools and the Australian official distribution agent for Amaco.

<https://www.ceramicartswa.asn.au/>

Established in 1993, the Ceramic Arts Association of WA (CAAWA) is a not for profit organisation run by members supporting the ceramics community in Western Australia. They aim to connect and promote all aspects of hand made pottery and ceramic sculpture.

<http://www.clayworksaustralia.com/>

Sell clay, brushes, hand tools, raw materials, equipment new and used, colours, glazes, decorating items.

<http://walkerceramics.com.au/>

Manufacturers of Australian clays and glazes by Walker Ceramics, Feeneys Clay and Cesco.

<https://keaneceramics.com.au/>

Keane Ceramics is one of the country's largest clay producers, suppliers and online retailer of our renowned clay range, pottery equipment, raw materials, tools and the Australian official distribution agent for Amaco.

<https://www.youtube.com/index>

Too much here to list, but just enter your area of interest in the search field and you will be inundated with videos to watch, some better than others, but a wealth of information.

<https://perthartglass.com.au>

Perth Art Glass online store

<https://www.etsy.com/au/c/art-and-collectibles?ref=catnav-66>

Etsy -To see what other artists are selling

<https://www.artslaw.com.au/>

Arts Law service - Your legal rights as an artist

<http://pixabay.com>

A source of reference images, free of copyright. Remember to read the fine print re usage rights.

<http://unsplash.com>

A source of reference images, free of copyright. Remember to read the fine print re usage rights.

<https://www.template maker.nl/en/shallowbox/>

THE BOX MAN

8 Karratha St, Welshpool

(08) 9351 8111

www.theboxman.com.au

Stock a range of generic sized "Heavy Duty" Art Boxes suitable for shipping locally and abroad.

They also do a run of custom made picture cartons daily, which if ordered by noon will be available for collection noon the following day.



PERTH ART GLASS

311 Stock Rd O'CONNOR WA 6163

Tel: +61-8-9314 5811

Shop Online: www.perthartglass.com.au

DISTRIBUTORS OF SPECIALTY GLASS & GLAZING PRODUCTS, ARTISTS IN GLASS

Our members receive discount on full sheets of glass and some other supplies from Perth Art Glass (but not hobby squares).

**MASTER PICTURE FRAMERS
GALLERY**

BLAIR BUCKINGHAM
PROPRIETOR

UNIT 1/1397 ALBANY HIGHWAY
CANNINGTON 6107

PH: 9350 5121 FAX: 9350 5101

bmb@masterframers.com.au

Many of our CAG artists use Master Picture Framers, Blair does an great job and is able to advise on suitable framing options for your precious work. Convenient location opposite Carousel Shopping Centre.

A Warm Welcome to our new members

As a member of Canning Arts, you join a group of enthusiastic artists, including potters, painters, glass artists, printmakers, textile artists and more! You will also enjoy discounted classes and workshops and use of the facilities and equipment at the Centre.

Members also have the unique opportunity to enter their artwork in Members' Exhibitions in the Centre Gallery and to display and sell work in various sales that are held throughout the year at community venues.

Club Keyholders

Jill Archibald 0407 995 649 | Chris Taylor 0427 571 513 | Trish Ray 0434 556 453



Scan with your phone camera to link to our Instagram page.



72 Riley Road, Cnr High Road
RIVERTON WA 6148
Phone: 0484 554 977
Email: office@canningartswa.org.au
Web: www.canningartswa.org.au



This Newsletter
is kindly printed by the
Office of Sam Lim
MP. Federal Member for Tangney